



Tooling Intelligence®

Introducing SmartBin

Weight-based inventory management solution



SUGGESTED APPLICATIONS:

- ⚙️ FASTENERS ⚙️ FITTINGS ⚙️ WELDING SUPPLIES
- ⚙️ CUTTING TOOLS ⚙️ SPARE / CRITICAL PARTS
- ⚙️ ELECTRONICS ⚙️ SENSORS ⚙️ SAFETY EQUIPMENT
- ⚙️ ELECTRONICAL CONNECTORS AND TERMINALS
- ⚙️ BEARINGS ⚙️ ABRASIVES ⚙️ SWITCHES
- ⚙️ NUTS ⚙️ BOLTS ⚙️ RIVETS ⚙️ TOOLS

toolingintelligence.co.uk

About SmartBin:

Introducing the exciting new SmartBin™, the weight-based, absolute-control, inventory management solution.

Engineered for precise control and tracking of bulk products, this electronically accessed cabinet efficiently caters to various sizes and types of durables and consumables.

SmartBin can be purchased as a standalone unit or seamlessly integrated with other bin or non-bin cabinets within the Smart Cabinet product line.

Going beyond conventional limitations, SmartBin comes in 4 fixed configurations. At the maximum capacity, SmartBin can accommodate 64 distinct SKU's and at the lowest capacity, can accommodate 30 SKU's.

Discover unparalleled tracking and control with SmartBin.

SmartBin™ delivers:

-  **Secure Access & Accountability:**
Ensure the security of your inventory through controlled access, maintaining precise accountability for every item.
-  **Speed of Transactions:**
SupplyPro's weight-based sensing technology significantly increases transaction speed and reduces restocking time.
-  **Efficiency & Productivity:**
Accurate tracking and control of bulk items providing efficient replenishment and productivity.
-  **Scalability:**
Effortlessly expand your inventory management capabilities by integrating additional cabinets.
-  **Real-time Visibility:**
Immediately gain insights into your inventory with real-time monitoring, tracking and reporting.
-  **Four Configurations:**
Choose the cabinet configuration to meet your specific product needs.

SmartBin™ features:

- SmartBin comes standard with an RFID badge reader to identify employee access to cabinet. Optional fixed barcode, magstripe or Wiegand readers are available.
- Available as a Main device with industrial touchscreen monitor and badge reader or as an Auxiliary device to other Smart Cabinet devices.
- Optimal product availability insight, utilizing SupplyPro's user-friendly cloud-based software and standard or customized reports and dashboards.

Configuration Options:

Configurations: (all lengths are 457mm)

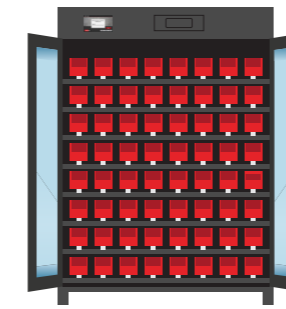

MAXIMUM-CAPACITY SMARTBIN

Can accommodate 64 SKU's

ROW	BIN SIZE (H x W) (mm)	# BINS
1	100 x 100	8
2	100 x 100	8
3	100 x 100	8
4	100 x 100	8
5	100 x 100	8
6	100 x 100	8
7	100 x 100	8
8	100 x 100	8
TOTAL		64



MEDIUM-CAPACITY 1 SMARTBIN

Can accommodate 50 SKU's

ROW	BIN SIZE (H x W) (mm)	# BINS
1	100 x 100	8
2	100 x 100	8
3	100 x 100	8
4	100 x 100	8
5	152 x 152	6
6	152 x 152	6
7	152 x 152	6
TOTAL		50

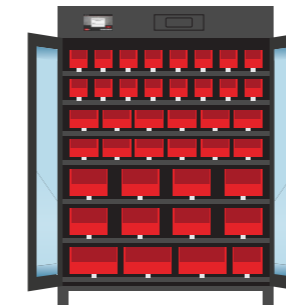

MEDIUM-CAPACITY 2 SMARTBIN

Can accommodate 40 SKU's

ROW	BIN SIZE (H x W) (mm)	# BINS
1	100 x 100	8
2	100 x 100	8
3	100 x 152	6
4	100 x 152	6
5	152 x 203	4
6	152 x 203	4
7	152 x 279	3
	152 x 152	1
TOTAL		40



LOW-CAPACITY SMARTBIN

Can accommodate 30 SKU's

ROW	BIN SIZE (H x W) (mm)	# BINS
1	152 x 152	6
2	152 x 152	6
3	152 x 152	6
4	152 x 203	4
5	152 x 203	4
6	152 x 279	3
	152 x 152	1
TOTAL		30

Dimensions: SmartBin comes in 4 fixed configurations.

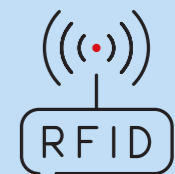
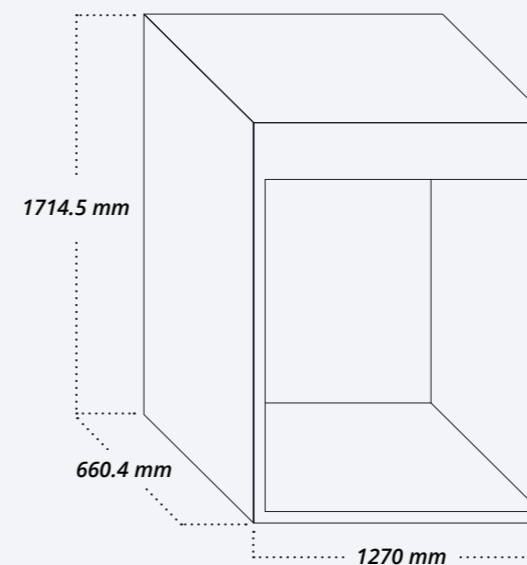

RFID badge reader is standard. Optional fixed barcode, magstripe and Wiegand readers are available.

Tooling Intelligence provides innovative inventory management solutions to organisations and industries across the United Kingdom and Europe.

We are experienced in providing state-of-the-art inventory management technology to our customers. We were founded in 2006 by a team of engineering experts and business specialists, who had the vision to combine cutting-edge solutions with premium customer service. We work with partners across numerous sectors, including aerospace, medical, precision engineering, oil and gas and many more.

Cutting-edge products

We have a broad range of products in our portfolio. Whether you are looking for a mobile inventory management solution for your on-the-go teams or a heavy-duty dispensing unit with complete visibility, you'll find something to suit your requirements with us.

Browse our website to learn more about our products or contact our experienced team for more information.

Access ongoing support

We know that the journey doesn't end once the installation is complete. We pride ourselves on our level of service, making sure you receive the support you need throughout the process. Whether you want to expand your existing inventory management solution or need technical help, our service team are always on hand to assist you.

Personalised service

We are an independent business, which means we always provide a high-quality, personalised service to our clients.

From the very start of your project, we work closely with you to find the right inventory management solution for your application. Our products are customisable too, which means we can help you design and create the ideal technology that meets your exact requirements.

Visit our centre

We understand that the best way to appreciate our products is to see them in action. That's why we invite our customers to our specialist Demonstration Centre to see the full potential of the solution in person.

Here, you can browse the full SupplyPro product range, as well as our service and support tools. You will have the opportunity to meet our knowledgeable team too.



Contact Us



01926 484511



toolingintelligence.co.uk



information@toolingintelligence.co.uk